



Seagate® Nytro® 5000

PCIe® Gen 3 x4 - NVMe 2.5" x 7mm
Product Manual



100810196, Rev.A
January 2018

Document Revision History

Revision	Date	Pages affected and description of change
Rev. A	January 2018	Initial release.

© 2018 Seagate Technology LLC. All rights reserved.

Publication number:100810196, Rev. A, January 2018

Seagate, Seagate Technology and the Spiral logo are registered trademarks of Seagate Technology LLC in the United States and/or other countries. Nytro and SeaTools are either trademarks or registered trademarks of Seagate Technology LLC or one of its affiliated companies in the United States and/or other countries. The FIPS logo is a certification mark of NIST, which does not imply product endorsement by NIST, the U.S., or Canadian governments. All other trademarks or registered trademarks are the property of their respective owners.

No part of this publication may be reproduced in any form without written permission of Seagate Technology LLC. Call 877-PUB-TEK1 (877-782-8351) to request permission.

When referring to drive capacity, one gigabyte, or GB, equals one billion bytes and one terabyte, or TB, equals one trillion bytes. Your computer's operating system may use a different standard of measurement and report a lower capacity. In addition, some of the listed capacity is used for formatting and other functions, and thus will not be available for data storage. Actual quantities will vary based on various factors, including file size, file format, features and application software. Actual data rates may vary depending on operating environment and other factors. The export or re-export of hardware or software containing encryption may be regulated by the U.S. Department of Commerce, Bureau of Industry and Security (for more information, visit www.bis.doc.gov), and controlled for import and use outside of the U.S. Seagate reserves the right to change, without notice, product offerings or specifications.

Contents

1.0	Scope	4
1.1	Models and Capacity	5
1.2	Performance	5
1.3	Power Consumption	5
1.4	Power Loss Data Protection	6
1.5	Out of Band Management (SMBus)	7
1.5.1	Vital Product Data (VPD)	8
1.5.2	SMBus Electrical Parameters	9
1.6	Environmental Conditions	9
1.6.1	Storage	9
1.7	Reliability	10
1.8	Endurance	11
2.0	Mechanical Information	12
2.1	Mechanical Dimensions and Weight - 2.5" Models	12
2.2	Bottom Cover Stiffness/Deflection	12
2.2.1	8639 Connector and Pin Descriptions	13
3.0	Interface requirements	16
3.1	PCIe features	16
3.2	Interface Commands Supported:	16
3.3	Log Page Support	17
3.4	SMART Attributes	18
4.0	Standards and Reference Documents	20
4.1	Regulatory Model Numbers	20
4.2	Standards	20
4.3	Agency and Safety Certifications	20
4.3.1	Safety Certification	20
4.3.2	Electromagnetic Compatibility	20
4.3.3	Electromagnetic susceptibility	20
4.3.4	Electromagnetic compliance	20
4.3.5	European Union (EU) CE Marking Requirements	21
4.3.6	Australian RCM Compliance Mark	21
4.3.7	Canada ICES-003	21
4.3.8	South Korean Certification Mark	21
4.3.9	Japan VCCI	21
4.3.10	Morocco Commodity Mark	22
4.3.11	Taiwanese BSMI	22
4.3.12	FCC verification	22
4.4	Environmental protection	23
4.4.1	European Union Restriction of Hazardous Substance Law	23
4.4.2	China Requirements —China RoHS 2	24
4.4.3	Taiwan Requirements — Taiwan RoHS	25
4.5	Reference Documents	26

Seagate Technology Support Services

For Nytro Support, visit: <http://www.seagate.com/support/by-product/ssd-and-pcie-flash/>

For information regarding online support and services, visit: <http://www.seagate.com/contacts/>

Available services include:

- Presales & Technical support
- Global Support Services telephone numbers & business hours
- Authorized Service Centers

For information regarding Warranty Support, visit: <http://www.seagate.com/support/warranty-and-replacements/>

For information regarding data recovery services, visit:

<http://www.seagate.com/services-software/seagate-recovery-services/recover/>

For Seagate OEM and Distribution partner and Seagate reseller portal, visit: <http://www.seagate.com/partners>

1.0 Scope

Seagate Nytro 5000 is a PCIe Gen 3 SSD, designed with the NVMe (Non-Volatile Memory Express) interface that delivers leading performance, low latency, and world class reliability and endurance.

- **Interface:**
 - PCIe Gen 3 x4 NVMe SSD
 - Out of Band Management (SMBus) management support
 - See [Section 1.6](#) for details.
- **Capacities:**
 - 800GB, 960GB, 1.6TB, 1.92TB.
 - See [Section 1.2](#) for details.
- **Components:**
 - 3D cMLC NAND Flash Memory
- **Form Factor:**
 - SFF 2.5 inch X 7mm
- **Power**
 - Lower power than current Enterprise class products (12.5W)
 - Power Loss Data Protection (PLDP)
 - Hot Plug capable
 - Idle Power: 2.5 2.8W
 - Average Read/Write Power: 6.7W(without Supercapacitor Learn cycle) 9.0W
 - See [Section 1.4](#) and [Section 1.5](#) for details.
- **Shock**
 - Operating/Non-Operating: 1500G @ 0.5ms (Gs)
- **Vibration**
 - Operating: 3.08 G_{RMS} (7-800Hz), 16.3 G_{RMS} (20-2000Hz)
- **Certification**
 - CE, BSMI, KCC, C-Tick, FCC, IC, UL, TUV, CB
- **Product Compliance**
 - RoHS
- **Reliability:**
 - Mean Time Between Failure (MTBF): 2 million hours
 - Data Retention: 3 months @ 40°C
 - Sector Sizes: 4096 and 512 bytes
 - Non-recoverable Read Errors per bits read: 1 per 10E16
 - See [Section 1.8](#) for details.
- **Endurance**
 - High Endurance models support up to 1.5 Drive Writes/day
 - Light Endurance models support up to 0.3 Drive Writes/day
 - See [Section 1.9](#) for details.
- **Temperature**
 - Operating: 0 to 70°C (as measured by SMART)
 - Non Operating: -40 to 85°C
 - See [Section 1.7](#) for details.
- **Airflow**
 -
 - See [Section 1.7](#) for details.
- **Performance**
 - Varies by capacity and endurance. See [Section 1.3](#) for details.
- **Security**
 - Self encryptions available
- **Warranty**
 - 5 years limited

1.1 Product Specifications

1.2 Models and Capacity

Table 1 Nytro 5000 2.5" 512 Sector Models and Capacities

Formatted Capacity	Standard 2.5" x 7 mm Models	SED 2.5" x 7 mm Models	512 bytes LBA Count
Target Application: Read-Intensive Workloads			
800GB	XP800HE10002	XP800HE10012	1,562,824,368
1600GB	XP1600HE10002	XP1600HE10012	3,125,627,568
Target Application: Mixed Workloads			
960GB	XP960LE10002	XP960LE10012	1,875,385,008
1920GB	XP1920LE10002	XP1920LE10012	3,750,748,848

1.3 Performance

Table 2 Performance

Specification	800GB	1600GB	960GB	1.92TB
Sequential Read (MB/s) Sustained, 128KB	2000	2000	2000	2000
Sequential Write (MB/s) Sustained, 128KB	1200	1200	1200	1200
Random Read (IOPS) Sustained, 4KB QD64	245,000	245,000	245,000	245,000
Random Write (IOPS) Sustained, 4KB QD64	60,000	67,000	25,000	28,000
Random 70/30 R/W (IOPS) Sustained, 4KB QD64	130,000	150,000	75,000	100,000

NOTE

More information on Performance:

- In certain performance metrics, performance of lower capacities are limited based on the number of active dies.
- **IOMeter:** Performance results are based on IOMeter. IOMeter is available at <http://sourceforge.net/projects/iometer/>. IOMeter is licensed under the Intel Open Source License and the GNU General Public License.
- **Response times:** Typical response times are measured under nominal conditions of temperature and voltage as measured on a representative sample of drives.
- **Measurements:** Measurements are performed on the drive after the workload reaches steady state, including all background activities required for normal operations.

1.4 Power Consumption

The 2.5" drive receives DC power (+12V) through the standard PCIe 8639 interface.

NOTE Here is more information on Power:

Table 3 DC Requirements

Supply Voltage	2.5"
Voltage Tolerances - nominal (%)	12V \pm 10%
DC Ripple/Noise	450mV Max: 50-150KHz 150mV Max: 10M-80M Hz
Rise Time (Max*/Min) *10% ~ 90% Nominal Voltage	100ms* /0s (hot-pluggable)
Fall Time (Min)	100 μ s @ 1A max discharge
Minimum Off Time	150ms
Inrush Current (Max Peak)	2A for <2ms

Table 4 Power

Specification	2.5"
Max Operating Power with Learn Cycle (W)	12.5
Power State 1 (W)	8.25
Power State 2 (W)	6.0
Power State 3 (W)	4.5

- NVMe Autonomous Power States are not supported.
- Typical power measurements are based on an average of drives tested under nominal conditions.
- Maximum power is defined as RMS over 100ms.
- Reduced performance might be observed for power states below the Max Operating Power.

1.5 Power Loss Data Protection

The drives implement an energy storage solution called Power Loss Data Protection. This circuit maintains power to the NAND while the NAND is being programmed, even if power to the system is interrupted. Power loss data protection ensures data integrity, and prevents loss of data and the resulting errors reporting back to the host.

1.6 Out of Band Management (SMBus)

The provides sub-system management data to the host over the SMBus interface at 0x6A.

Table 5 Out of Band Management (SMBus) Protocol

Command Code	Offset (byte)	Description																
0	00	Length of Status: Indicates number of additional bytes to read before encountering PEC. This value should always be 6 (06h) in implementations of this version of the spec.																
	01	<p>Status Flags (SFLGS): This field indicates the status of the NVM subsystem.</p> <p>SMBus Arbitration – Bit 7 is set ‘1’ after a SMBus block read is completed all the way to the stop bit without bus contention and cleared to ‘0’ if a SMBus Send Byte FFh is received on this SMBus slave address.</p> <p>Drive Not Ready – Bit 6 is set to ‘1’ when the subsystem cannot process NVMe management commands, and the rest of the transmission may be invalid. If cleared to ‘0’, then the NVM subsystem is fully powered and ready to respond to management commands. This logic level intentionally identifies and prioritizes powered up and ready drives over their powered off neighbors on the same SMBus segment.</p> <p>Drive Functional – Bit 5 is set to ‘1’ to indicate an NVM subsystem is functional. If cleared to ‘0’, then there is an unrecoverable failure in the NVM subsystem and the rest of the transmission may be invalid.</p> <p>Reset Not Required - Bit 4 is set to ‘1’ to indicate the NVM subsystem does not need a reset to resume normal operation. If cleared to ‘0’ then the NVM subsystem has experienced an error that prevents continued normal operation. A controller reset is required to resume normal operation.</p> <p>Port 0 PCIe Link Active - Bit 3 is set to ‘1’ to indicate the first port’s PCIe link is up (i.e., the Data Link Control and Management State Machine is in the DL_Active state). If cleared to ‘0’, then the PCIe link is down.</p> <p>Port 1 PCIe Link Active - Bit 2 is set to ‘1’ to indicate the second port’s PCIe link is up. If cleared to ‘0’, then the second port’s PCIe link is down or not present.</p> <p>Bits 1-0 shall be set to ‘1’.</p>																
	02	<p>SMART Warnings: This field shall contain the Critical Warning field (byte 0) of the NVMe SMART / Health Information log. Each bit in this field shall be inverted from the NVMe definition (i.e., the management interface shall indicate a ‘0’ value while the corresponding bit is ‘1’ in the log page). See the NVMe specification for bit definitions.</p> <p>If there are multiple controllers in the NVM subsystem, the management endpoint shall combine the Critical Warning field from every controller such that a bit in this field is: Cleared to ‘0’ if any controller in the subsystem indicates a critical warning for that corresponding bit. Set to ‘1’ if all controllers in the NVM subsystem do not indicate a critical warning for the corresponding bit.</p>																
	03	<p>Composite Temperature (CTemp): This field indicates the current temperature in degrees Celsius. If a temperature value is reported, it should be the same temperature as the Composite Temperature from the SMART log of hottest controller in the NVM subsystem. The reported temperature range is vendor specific, and shall not exceed the range -60 to +127°C. The 8 bit format of the data is shown below.</p> <p>This field should not report a temperature when that is older than 5 seconds. If recent data is not available, the NVMe management endpoint should indicate a value of 80h for this field.</p> <table border="1"> <thead> <tr> <th>Value</th> <th>Description</th> </tr> </thead> <tbody> <tr> <td>00h-7Eh</td> <td>Temperature is measured in degrees Celsius (0 to 126C)</td> </tr> <tr> <td>7Fh</td> <td>127C or higher</td> </tr> <tr> <td>80h</td> <td>No temperature data or temperature data is more the 5 seconds old.</td> </tr> <tr> <td>81h</td> <td>Temperature sensor failure</td> </tr> <tr> <td>82h-C3h</td> <td>Reserved</td> </tr> <tr> <td>C4</td> <td>Temperature is -60C or lower</td> </tr> <tr> <td>C5-FFh</td> <td>Temperature measured in degrees Celsius is represented in twos complement (-1 to -59C)</td> </tr> </tbody> </table>	Value	Description	00h-7Eh	Temperature is measured in degrees Celsius (0 to 126C)	7Fh	127C or higher	80h	No temperature data or temperature data is more the 5 seconds old.	81h	Temperature sensor failure	82h-C3h	Reserved	C4	Temperature is -60C or lower	C5-FFh	Temperature measured in degrees Celsius is represented in twos complement (-1 to -59C)
	Value	Description																
	00h-7Eh	Temperature is measured in degrees Celsius (0 to 126C)																
	7Fh	127C or higher																
	80h	No temperature data or temperature data is more the 5 seconds old.																
81h	Temperature sensor failure																	
82h-C3h	Reserved																	
C4	Temperature is -60C or lower																	
C5-FFh	Temperature measured in degrees Celsius is represented in twos complement (-1 to -59C)																	
04	<p>Percentage Drive Life Used (PDLU): Contains a vendor specific estimate of the percentage of NVM subsystem NVM life used based on the actual usage and the manufacturer’s prediction of NVM life. If an NVM subsystem has multiple controllers the highest value is returned. A value of 100 indicates that the estimated endurance of the NVM in the NVM subsystem has been consumed, but may not indicate an NVM subsystem failure. The value is allowed to exceed 100. Percentages greater than 254 shall be represented as 255. This value should be updated once per power-on hour and equal the Percentage Used value in the NVMe SMART Health Log Page.</p>																	
06 : 05	Reserved: Shall be set to 0000h.																	
07	PEC: An 8 bit CRC calculated over the slave address, command code, second slave address and returned data. Algorithm is in SMBus Specifications.																	

Table 5 Out of Band Management (SMBus) Protocol (continued)

Command Code	Offset (byte)	Description
8	08	Length of identification: Indicates number of additional bytes to read before encountering PEC. This value should always be 22 (16h) in implementations of this version of the spec.
	10 : 09	Vendor ID: The 2 byte vendor ID, assigned by the PCI SIG. Should match VID in the Identify Controller command response. MSB is transmitted first.
	30 : 11	Serial Number: 20 characters that match the serial number in the NVMe Identify Controller command response. First character is transmitted first.
	31	PEC: An 8 bit CRC calculated over the slave address, command code, second slave address and returned data. Algorithm is in SMBus Specifications.
32+	255 : 32	Vendor Specific: This data structure shall not exceed the maximum read length of 255 specified in the SMBus version 3 specification. Preferably length is not greater than 32 for compatibility with SMBus 2.0, additional blocks shall be on 8 byte boundaries.

NOTE You can find a description of sub-system management data to the host over the SMBus interface in the *NVM Express Management Interface 1.0*.

1.6.1 Vital Product Data (VPD)

The drives access a Vital Product Data (VPD) EEPROM page as listed below through address 0xA6. This requires 3.3V Auxiliary voltage.

Table 6 VPD Structure

Address	Function	Type	Size (B)	Default Size	Description
0	Class Code	RO	3	Vendor	Device type and programming interface
3	ID	RO	2	Vendor	PCI-SIG Vendor ID
5			20	Vendor	Serial Number (vendor unique)
25			40	Vendor	Model Number (ASCII string)
65	PCIe Port 0 Capabilities	RO	2	Vendor	Maximum Link Speed
66					Maximum Link Width
67	PCIe Port 1 Capabilities	RO	2	Vendor	Maximum Link Speed
68					Maximum Link Width
69	Initial Power Requirements	RO	3	Vendor	12V power rail initial power requirement (W)
70				0	Reserved
71				0	Reserved
72	Maximum Power Requirements	RO	3	Vendor	12V power rail initial power requirement (W)
73				0	Reserved
74				0	Reserved
75	Capability List Pointer	RO	2	Vendor	16-bit address pointer to start of capability list (zero means no capability list)

NOTE Initial and Maximum Power requirements are not supported.

1.6.2 SMBus Electrical Parameters

The SMBus interface operates only when 3.3V_AUX is supplied to the drive. When 3.3V_AUX and 12V are supplied to the drive, the SMBus interface functions fully. When only 3.3V_AUX is supplied to the drive (12V off), VPD data remains accessible over the SMBus interface, but other functions are unavailable. No specific sequencing is needed for the 12V and 3.3V_AUX input voltages.

Table 7 SMBus Electrical Parameters

Specification	Values
3.3V Auxiliary Voltage Supply	2.8V - 3.8V
3.3V Auxiliary Maximum Continuous Current	
SMBus Idle	20µA
SMBus Active	1mA
3.3V Auxiliary Maximum Capacitive Load	5µF

1.7 Environmental Conditions

Table 8 Temperature and Humidity

Specification	Temperature / Humidity
Temperature (°C)	Operating (as measured by SMART) Non-Operating
	0 to 70 -40 to 85 ¹
Temperature Gradient Maximum	Operating Non-Operating
	30°C/hr 30°C/hr
Humidity	Operating Non-Operating
	5%-95% 5%-95%

NOTE 1. Limited to shelf life while product is still in the shipping package.

1.7.1 Storage

You can store the drive for a maximum of 180 days in the original unopened Seagate shipping package or 60 days, unpackaged, in the defined non-operating limits (See [Table 8, Temperature and Humidity](#)). You can extend storage to 1 year packaged or unpackaged under optimal environmental conditions (<40°C, <40% relative humidity non-condensing, and non-corrosive environment).

Table 9 Shock

Specification	Shock
Shock - Maximum	Operating / Non Operating
	1500 G at 0.5 ms

NOTE Specification does not cover connection issues that might result from testing at this level.

- **Operating shock:** The drive, as installed for normal operation, operates error free while subjected to intermittent shock not exceeding the specification. Shock may be applied in the X, Y, or Z-axis. Shock is not to be repeated more than once every 2 seconds.
- **Non-Operating shock:** The limits of non-operating shock apply to all conditions of handling and transportation. This includes isolated drive and integrated drives. Shock may be applied in the X, Y, or Z-axis.

Table 10 Vibration

Specification		Vibration
Vibration - Profile	Operating	3.08 G _{RMS} (7-800Hz), 16.3 G _{RMS} (20-2000Hz)

NOTE

More information on Vibration:

- **Operating vibration:** The drive, as installed for normal operation, shall operate error free while subjected to specified vibration not exceeding specification. Vibration may be applied in the X, Y, or Z-axis.

Table 11 Airflow Requirements

Airflow Definition	Unit	Ambient Temperature	Airflow
Airflow Along Drive	LFM	35°C	412

NOTE

More information on Airflow:

- It is recommended that airflow for 2.5-inch form factor should be towards the server, from the non-connector side to the connector side. Airflow is specified across the surface of the drive. Spacing all sides is assumed to be 3mm.

1.8 Reliability

Table 12 Reliability

Specification	Reliability Data
Mean Time Between Failures (MTBF)	2 million hours
Data Retention	3 months @ 40°C
Non-recoverable Read Errors per bits read	1 per 10E16

NOTE

Here is more information on Reliability:

- **MTBF** specification is based on these assumptions for Enterprise Storage System environments: 8760 power on hours per year, 250 power on/off cycles per year, and nominal voltages. The drive achieves specified MTBF when operating in an environment that ensures the case temperatures do not exceed the temperature specifications.
- **Data Retention** is the time that NAND retains data at maximum rated endurance

1.9 Endurance

Table 13 2.5" - High Endurance Models

Capacity	Model	SED/Standard	Endurance - Drive Writes Per Day
800GB	XP800HE10002	Standard	1.5
	XP800HE10012	SED	1.5
1600GB	XP1600HE10002	Standard	1.5
	XP1600HE10012	SED	1.5

Table 14 2.5" - High Capacity Models

Capacity	Model	SED/Standard	Endurance - Drive Writes Per Day
960GB	XP960LE10002	Standard	0.3
	XP960LE10012	SED	0.3
1920GB	XP1920LE10002	Standard	0.3
	XP1920LE10012	SED	0.3

NOTE

Endurance rating is the expected amount of host data that can be written by product when subjected to a specified workload at a specified operating and storage temperature over the specified product life. For the specific workload to achieve this level of endurance, *please refer to JEDEC Specification JESD218*. Terabyte Writes is defined as 1×10^{12} Bytes.

2.0 Mechanical Information

2.1 Mechanical Dimensions and Weight - 2.5" Models

Weight: 2.5" models 0.198 pounds 90 grams

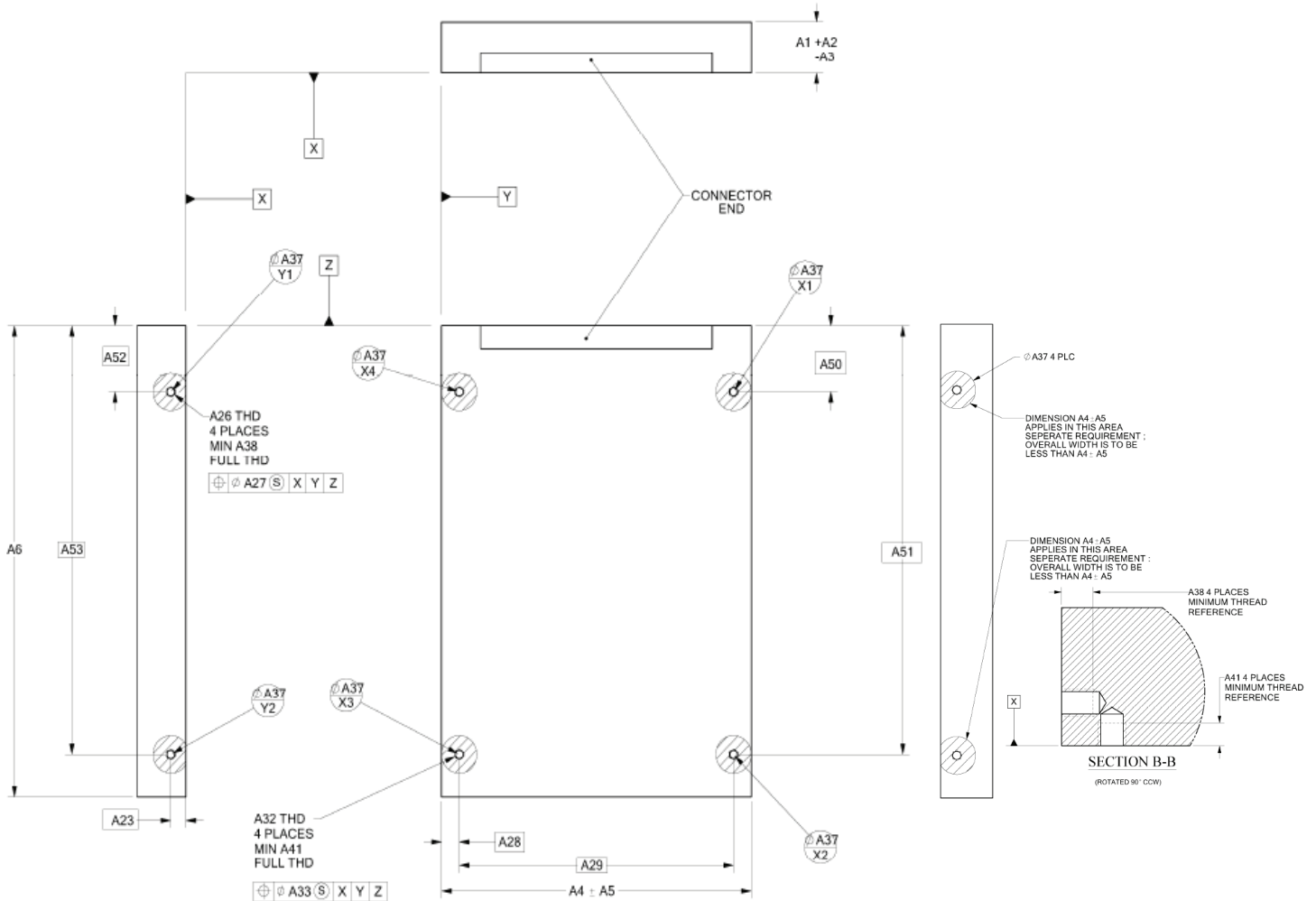

Figure 1. Configuration dimensions (2.5" models)

NOTE These dimensions conform to the Small Form Factor Standard documented in SFF-8200 and SFF-8639. The latest revisions may be found at www.sffcommittee.org.

2.2 Bottom Cover Stiffness/Deflection

Table 15 Bottom Cover Stiffness/Deflection

Operating: No uncorrectable errors	10mm probe: 1.02kgf or 5mm probe: 0.92kgf
Non-Operating: No uncorrectable errors	20mm probe: 2.0kgf on any point on bottom cover

2.2.1 8639 Connector and Pin Descriptions

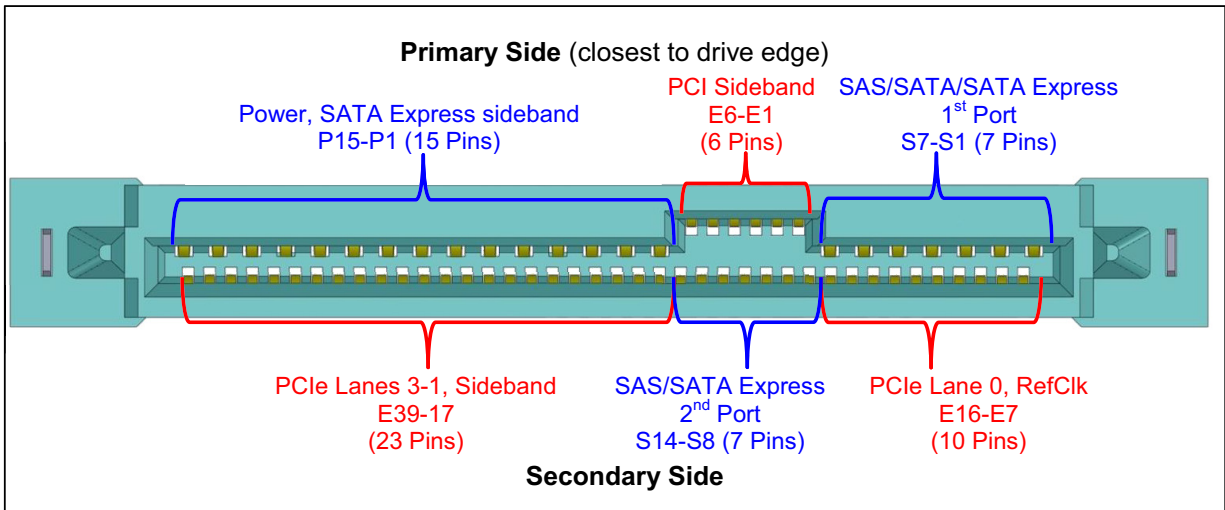

Figure 2. 8639 Connector

NOTE

To see the latest specification for the physical 8639 connector, refer to www.pcisig.com website and the latest PCI Express Electromechanical specification.

2.2.1.1 PCIe 8639 Pin Descriptions

Pin	Name	Description	Pin	Name	Description
S1	GND	Ground	E7	REFCLK0	Reference Clock Port 0 Positive
S2	NU	Not Used	E8	REFCLK0-	Reference Clock Port 0 Negative
S3	NU	Not Used	E9	GND	Ground
S4	GND	Ground	E10	PETp0	Transmitter differential pair, Lane 0 Positive
S5	NU	Not Used	E11	PETn0	Transmitter differential pair, Lane 0 Negative
S6	NU	Not Used	E12	GND	Ground
S7	GND	Ground	E13	PERn0	Receiver differential pair, Lane 0 Negative
E1	NU	Not Used	E14	PERp0	Receiver differential pair, Lane 0 Positive
E2	NU	Not Used	E15	GND	Ground
E3	3.3V_AUX	3.3V Auxiliary Power (Required for SMBus operation)	E16	RSVD	Reserved (Seagate Internal)
E4	NU	Not Used	S8	GND	Ground
E5	PERST0#	Fundamental reset port 0	S9	NU	Not Used
E6	RSVD	Reserved (Seagate Internal)	S10	NU	Not Used
P1	NU	Not Used	S11	GND	Ground
P2	NU	Not Used	S12	NU	Not Used
P3	CLKREQ#	Clock Request	S13	NU	Not Used
P4	IfDet#	Interface Detect (drive type)	S14	GND	Ground
P5	GND	Ground	S15	RSVD	Reserved (Seagate Internal)
P6	GND	Ground	S16	GND	Ground
P7	NU	Not Used	S17	PETp1	Transmitter differential pair, Lane 1 Positive
P8	NU	Not Used	S18	PETn1	Transmitter differential pair, Lane 1 Negative
P9	NU	Not Used	S19	GND	Ground
P10	PRSNT#	Presence Detect (also used for drive type)	S20	PERn1	Receiver differential pair, Lane 1 Negative
P11	ACT	Activity signal from the drive	S21	PERp1	Receiver differential pair, Lane 1 Positive
P12	Hot-Plug	Ground	S22	GND	Ground
P13	+12V_pre	12V Power	S23	PETp2	Transmitter differential pair, Lane 2 Positive
P14	+12V	12V Power	S24	PETn2	Transmitter differential pair, Lane 2 Negative
P15	+12V	12V Power	S25	GND	Ground
			S26	PERn2	Receiver differential pair, Lane 2 Negative
			S27	PERp2	Receiver differential pair, Lane 2 Positive
			S28	GND	Ground

			E17	PETp3	Transmitter differential pair, Lane 3 Positive
			E18	PETn3	Transmitter differential pair, Lane 3 Negative
			E19	GND	Ground
			E20	PERn3	Receiver differential pair, Lane 3 Negative
			E21	PERp3	Receiver differential pair, Lane 3
			E22	GND	Ground
			E23	SMCLK	SMBus clock
			E24	SMDATA	SMBus data
			E25	NU	Not Used

3.0 Interface requirements

3.1 PCIe features

The Seagate Nytro SSD supports NVMe spec 1.2a. Below is a table showing the supported Features, Op-code, and whether vendor specific, mandatory, or optional.

Table 16 PCIe Features

Feature ID	M/O	Description	Supported
01h	M	Arbitration	Yes
02h	M	Power Management	Yes
03h	O	LBA Range Type	No
04h	M	Temperature Threshold	Yes
05h	M	(Time limited) Error Recovery	Yes
06h	O	Volatile Write Cache	No
07h	M	Number of Queues	Yes
08h	M	Interrupt Coalescing	Yes
09h	M	Interrupt Vector Configuration	Yes
0Ah	O	Write Atomicity	No
0Bh	M	Asynchronous Event Configuration	Yes
0Ch	O	Autonomous Power State Transition	No
0Dh	O	Host Memory Buffer	No
80h	O	Software Progress Marker	No
81h	O	Host Identifier	No
82h	O	Reservation Notification Mask	No
83h	O	Reservation Persistence	No
C0h	VS	System Time	Yes
C1h	VS	Test Unit Ready	Yes
C2h	VS	Media Life Left Threshold	Yes

3.2 Interface Commands Supported:

The Seagate Nytro SSD supports all the mandatory NVMe Admin and I/O command-sets in *NVMe spec 1.2a*. In addition, several optional commands are also supported. Below are tables showing the Commands, Op-code, whether Admin or IO and mandatory or optional:

Table 17 Supported I/O Commands

Feature ID	M/O	Command	Supported
00h	M	Flush	Yes
01h	M	Write	Yes
02h	M	Read	Yes
04h	O	Write Uncorrectable	Yes
05h	O	Compare	No
08h	O	Write Zones	Yes
09h	O	Dataset Management - Trim	Yes
		Dataset Management - IDW	No
		Dataset Management - IDR	No

Table 17 Supported I/O Commands (continued)

Feature ID	M/O	Command	Supported
0Dh	O	Reservation Register	No
0Eh	O	Reservation Report	No
11h	O	Reservation Acquire	No
12h	O	Reservation Release	No

Table 18 Supported Admin Commands

Op-code	M/O	Command	Supported
00h	M	Delete I/O SQ	Yes
01h	M	Create I/O SQ	Yes
02h	M	Get log Page	Yes
04h	M	Delete I/O CQ	Yes
05h	M	Create I/O CQ	Yes
06h	M	Identify	Yes
08h	M	Abort	Yes
09h	M	Set Features	Yes
0Ah	M	Get Features	Yes
0Ch	M	Async Event Request	Yes
0Dh	O	Namespace Management	No
10h	M	Firmware Commit	Yes
11h	M	Firmware Image Download	Yes
15h	O	Namespace Attachment	No
80h	O	Format NVM	Yes
81h	O	Security Send	Yes
82h	O	Security Receive	Yes
C0h	VS	Diagnostic Send	Yes
C1h	VS	Diagnostic Receive	Yes

3.3 Log Page Support

The Seagate Nytro SSD supports the following mandatory log pages defined in NVMe 1.2a specification.

Table 19 Log Page Support

Log Page	M/O	Description	Supported
01h	M	Error Information	Yes
02h	M	SMART/Health Information	Yes
03h	M	Firmware Slot Information	Yes
05h	O	Commands Supported and Effects Log	Yes
C4h	VS	Extended SMART Attributes	Yes
C5h	VS	List of Supported Log Pages	Yes
C8h	VS	Recent history Log Page	Yes
CBh	VS	PCIe Error Counter Log	Yes

3.4 SMART Attributes

The following table lists the supported SMART attributes.

Table 20 SMART Attributes (Log Identifier 02h)

Byte	# of Bytes	Attribute	Description
0	1	Critical Warning: These bits, if set, flag various warning sources. Bit 0: Available Spare is below Threshold Bit 1: Temperature has exceeded Threshold Bit 2: Reliability is degraded due to excessive media or internal errors Bit 3: Media is placed in Read- Only Mode Bit 4: Volatile Memory Backup System has failed (e.g., enhanced power loss capacitor test failure) Bits 5-7: Reserved	Any of the critical warning can be tied to asynchronous event notification. Drive Health Indicator defined under bytes 3095-3076 of Identify Controller may still indicate "healthy" status when the critical warning flag is set.
1	2	Temperature: Overall Device current temperature in Kelvin	For AIC, this reports the NAND temperature, for 2.5-inch FF, this reports the case temperature,
3	1	Available Spare: Contains a normalized percentage (0 to 100%) of the remaining spare capacity available	Starts from 100 and decrements.
4	1	Available Spare Threshold	Threshold is set to 10%.
5	1	Percentage Used Estimate (Value allowed to exceed 100%)	A value of 100 indicates that the estimated endurance of the device has been consumed, but may not indicate a device failure. The value is allowed to exceed 100. Percentages greater than 254 shall be represented as 255. This value shall be updated once per power-on hour (when the controller is not in a sleep state).
32	16	Data Units Read (in LBAs)	Contains the number of 512 byte data units the host has read from the controller; this value does not include metadata. This value is reported in thousands (i.e., a value of 1 corresponds to 1000 units of 512 bytes read) and is rounded up. When the LBA size is a value other than 512 bytes, the controller shall convert the amount of data read to 512-byte units.
48	16	Data Units Write (in LBAs)	Contains the number of 512 byte data units the host has written to the controller; this value does not include metadata. This value is reported in thousands (i.e., a value of 1 corresponds to 1000 units of 512 bytes written) and is rounded up. When the LBA size is a value other than 512 bytes, the controller shall convert the amount of data written to 512-byte units. For the NVM* command set, logical blocks written as part of Write operations shall be included in this value. Write Uncorrectable commands shall not impact this value.
64	16	Host Read Commands	Contains the number of read commands issued to the controller.
80	16	Host Write Commands	Contains the number of write commands issued to the controller.

Table 20 SMART Attributes (Log Identifier 02h) (continued)

Byte	# of Bytes	Attribute	Description
96	16	Controller Busy Time (in minutes)	Contains the amount of time the controller is busy with I/O commands. The controller is busy when there is a command outstanding to an I/O Queue (specifically, a command was issued by way of an I/O Submission Queue Tail doorbell write and the corresponding completion queue entry has not been posted yet to the associated I/O Completion Queue). This value is reported in minutes.
112	16	Power Cycles	Contains the number of power cycles.
128	16	Power On Hours	Contains the number of power-on hours. This does not include time that the controller was powered and in a low power state condition.
144	16	Unsafe Shutdowns	Contains the number of unsafe shutdowns. This count is incremented when a shutdown notification (CC.SHN) is not received prior to loss of power.
160	16	Media Errors	Contains the number of occurrences where the controller detected an unrecovered data integrity error. Errors such as uncorrectable ECC, CRC checksum failure, or LBA tag mismatch are included in this field.
176	16	Number of Error Information Log Entries	Contains the number of Error Information log entries over the life of the controller.

4.0 Standards and Reference Documents

Each Hard Drive and Solid State Drive ("drives") has a product label that includes certifications that are applicable to that specific drive. The following information provides an overview of requirements that may be applicable to the drive.

4.1 Regulatory Model Numbers

The following model numbers represent the indicated form factors and features of all configurations within the series: Regulatory Models as Documented in the Declaration of Conformity (DoC):

- STA004 - (represents U.2)

4.2 Standards

The drives are recognized in accordance with UL 60950-1 as tested by UL, CSA 60950-1 as tested by CSA, and EN60950-1 as tested by TUV.

4.3 Agency and Safety Certifications

4.3.1 Safety Certification

These products are certified to meet the requirements of UL/cUL 60950-1, EN 60950-1, and may also include, IEC 62368, UL 62368 and EN 62368.

4.3.2 Electromagnetic Compatibility

The drive, as delivered, is designed for system integration and installation into a suitable enclosure prior to use. The drive is supplied as a subassembly and is not subject to Subpart B of Part 15 of the FCC Rules and Regulations nor the Radio Interference Regulations of the Canadian Department of Communications.

The design characteristics of the drive serve to minimize radiation when installed in an enclosure that provides reasonable shielding. The drive is capable of meeting the Class B limits of the FCC Rules and Regulations of the Canadian Department of Communications when properly packaged; however, it is the user's responsibility to assure that the drive meets the appropriate EMI requirements in their system. Shielded I/O cables may be required if the enclosure does not provide adequate shielding. If the I/O cables are external to the enclosure, shielded cables should be used, with the shields grounded to the enclosure and to the host controller.

4.3.3 Electromagnetic susceptibility

The drive as delivered is tested to meet susceptibility requirements in a representative enclosure. It is the responsibility of those integrating the drive within their systems to perform those tests required and design their system to ensure that equipment operating in the same system as the drive or external to the system does not adversely affect the performance of the drive. See Section 1.4, "Power Consumption."

4.3.4 Electromagnetic compliance

Seagate uses an independent laboratory to confirm compliance with the directives/standards for CE Marking and C-Tick Marking. The drive was tested in a representative system for typical applications. The selected system represents the most popular characteristics for test platforms. The system configurations include:

- Typical current use microprocessor
- Keyboard
- Monitor/display
- Printer
- Mouse

Although the test system with this Seagate model complies with the directives/standards, we cannot guarantee that all systems will comply. The computer manufacturer or system integrator shall confirm EMC compliance and provide the appropriate marking for their product.

4.3.5 European Union (EU) CE Marking Requirements

Drives that display the CE mark comply with the European Union (EU) requirements specified in the Electromagnetic Compatibility Directive (2014/30/EU) put into force on 20 April 2016. Testing is performed to the levels specified by the product standards for Information Technology Equipment (ITE). Emission levels are defined by EN 55032:2012, Class B and the immunity levels are defined by EN 55024:2010.

The drives also meet the requirements of The Low Voltage Directive (LVD) 2014/35/EU.

Seagate drives are tested in representative end-user systems. Although CE-marked Seagate drives comply with all relevant regulatory requirements and standards for the drives, Seagate cannot guarantee that all system-level products into which the drives are installed comply with all regulatory requirements and standards applicable to the system-level products. The drive is designed for operation inside a properly designed system (e.g., enclosure designed for the drive), with properly shielded I/O cable (if necessary) and terminators on all unused I/O ports. Computer manufacturers and system integrators should confirm EMC compliance and provide CE marking for the system-level products.

For compliance with the RoHS "Recast" Directive 2011/65/EU (RoHS 2), see [Section 4.4.1 on page 23](#).

4.3.6 Australian RCM Compliance Mark

If this model has the RCM Marking it complies with the Australia/New Zealand Standard AS/NZ CISPR22 and meets the Electromagnetic Compatibility (EMC) Framework requirements of the Australian Communications and Media Authority (ACMA).

4.3.7 Canada ICES-003

If this model has the ICES-003:2016 marking it complies with requirements of ICES tested per ANSI C63.4-2014.

4.3.8 South Korean Certification Mark

The South Korean KC Certification Mark means the drives comply with paragraph 1 of Article 11 of the Electromagnetic Compatibility control Regulation and meet the Electromagnetic Compatibility (EMC) Framework requirements of the Radio Research Agency (RRA) Communications Commission, Republic of Korea. These drives have been tested and comply with the Electromagnetic Interference/Electromagnetic Susceptibility (EMI/EMS) for Class B products. Drives are tested in a representative, end-user system by a Korean-recognized lab.

기종별	사용자안내문
B급 기기 (가정용 방송통신기자재)	이 기기는 가정용(B급) 전자파적합기기로서 주로 가정에서 사용하는 것을 목적으로 하며, 모든 지역에서 사용할 수 있습니다.

4.3.9 Japan VCCI

この装置は、情報処理装置等電波障害自主規制協議会（VCCI）の基準に基づくクラスB情報技術装置です。この装置は、家庭環境で使用することを目的としていますが、この装置がラジオやテレビジョン受信機に近接して使用されると、受信障害を引き起こすことがあります。
取扱説明書に従って正しい取り扱いをして下さい。

This is a Class B product based on the standard of the Voluntary Control Council for Interference from Information Technology Equipment (VCCI). If this is used near a radio or television receiver in a domestic environment, it may cause radio interference. Install and use the equipment according to the instruction guide.

4.3.10 Morocco Commodity Mark

Seagate drives are tested for compliance and comply with the European Union (EU) Electromagnetic Compatibility (EMC) Directive 2014/30/EU and the Low Voltage Directive (LVD) 2014/35/EU. Accordingly, the drives also meet the requirements of Morocco's Order of the Minister of Industry, Trade, Investment and Digital Economy No. 2574-14 of 29 Ramadan 1436 (16 July 2015) on electromagnetic compatibility of equipment.

For drives with the Morocco Mark, Seagate has added the Moroccan Commodity Mark to the drives provided to the OEM for the sale of Customer Kits produced by our OEM customers that are intended to be incorporated into the OEM's finished system-level product by an end user. The Customer Kits are considered 'devices' under Morocco's Order of the Minister of Industry, Trade, Investment and Digital Economy No. 2574-14 of 29 Ramadan 1436 (16 July 2015) on electromagnetic compatibility of equipment.

4.3.11 Taiwanese BSMI

Drives with the Taiwanese certification mark comply with Chinese National Standard, CNS13438.

For compliance with the Taiwan Bureau of Standards, Metrology and Inspection's (BSMI) requirements, [see Section 4.4.3 on page 25](#).

4.3.12 FCC verification

These drives are intended to be contained solely within a personal computer or similar enclosure (not attached as an external device). As such, each drive is considered to be a subassembly even when it is individually marketed to the customer. As a subassembly, no Federal Communications Commission verification or certification of the device is required.

Seagate has tested this device in enclosures as described above to ensure that the total assembly (enclosure, disk drive, motherboard, power supply, etc.) does comply with the limits for a Class B computing device, pursuant to Subpart J, Part 15 of the FCC rules. Operation with noncertified assemblies is likely to result in interference to radio and television reception.

Radio and television interference. This equipment generates and uses radio frequency energy and if not installed and used in strict accordance with the manufacturer's instructions, may cause interference to radio and television reception.

This equipment is designed to provide reasonable protection against such interference in a residential installation. However, there is no guarantee that interference will not occur in a particular installation. If this equipment does cause interference to radio or television, which can be determined by turning the equipment on and off, users are encouraged to try one or more of the following corrective measures:

- Reorient the receiving antenna.
- Move the device to one side or the other of the radio or TV.
- Move the device farther away from the radio or TV.
- Plug the computer into a different outlet so that the receiver and computer are on different branch outlets.

If necessary, users should consult a dealer or an experienced radio/television technician for additional suggestions. Users may find helpful the following booklet prepared by the Federal Communications Commission: *How to Identify and Resolve Radio-Television Interference Problems*. This booklet is available from the Superintendent of Documents, U.S. Government Printing Office, Washington, DC 20402. Refer to publication number 004-000-00345-4.

4.4 Environmental protection

Seagate designs its products to meet environmental protection requirements worldwide, including regulations restricting certain chemical substances.

4.4.1 European Union Restriction of Hazardous Substance Law

4.4.1.1 Restriction of Hazardous Substances in Electrical and Electronic Equipment

Seagate drives are designed to be compliant with the European Union RoHS "Recast" Directive 2011/65/EU (RoHS 2) as amended by Directive (EU) 2015/863. The RoHS2 restricts the use of certain hazardous substances such as Lead, Cadmium, Mercury, Hexavalent Chromium, Polybrominated Biphenyls (PBB) and Polybrominated Diphenyl Ether (PBDE), BisBis(2-Ethylhexyl) phthalate (DEHP), Benzyl butyl phthalate (BBP), Dibutyl phthalate (DBP), and Diisobutyl phthalate (DIBP) in electrical and electronic equipment (EEE).

4.4.1.2 Substances of Very High Concern (SVHC)

The European Union REACH (Registration, Evaluation, Authorization and Restriction of Chemicals) Regulation (EC) 1907/2006 regulates chemicals shipped into and used in Europe. A number of parts and materials in Seagate products are procured from external suppliers. We rely on the representations of our suppliers regarding the presence of REACH substances in these articles and materials. Our supplier contracts require compliance with our chemical substance restrictions, and our suppliers document their compliance with our requirements by providing full-disclosure material content declarations that disclose inclusion of any REACH-regulated substance in such articles or materials. Product-specific REACH declarations are available upon request through your Seagate Sales Representative.

4.4.2 China Requirements — China RoHS 2



China RoHS 2 refers to the Ministry of Industry and Information Technology Order No. 32, effective July 1, 2016, titled Management Methods for the Restriction of the Use of Hazardous Substances in Electrical and Electronic Products. To comply with China RoHS 2, Seagate determined this product's Environmental Protection Use Period (EPUP) to be 20 years in accordance with the *Marking for the Restricted Use of Hazardous Substances in Electronic and Electrical Products*, SJT 11364-2014.

Table 21 China - Hazardous Substances

	有害物质 Hazardous Substances					
	铅 (Pb)	汞 (Hg)	镉 (Cd)	六价铬 (Cr ⁺⁶)	多溴联苯 (PBB)	多溴二苯醚 (PBDE)
印刷电路板组装 PCBA	X	O	O	O	O	O
机壳 Chassis	X	O	O	O	O	O

本表格依据 SJ/T 11364 的规定编制。

This table is prepared in accordance with the provisions of SJ/T 11364-2014

O: 表示该有害物质在该部件所有均质材料中的含量均在 GB/T 26572 规定的限量要求以下。

O: Indicates that the hazardous substance contained in all of the homogeneous materials for this part is below the limit requirement of GB/T26572.

X: 表示该有害物质至少在该部件的某一均质材料中的含量超出 GB/T 26572 规定的限量要求。

X: Indicates that the hazardous substance contained in at least one of the homogeneous materials used for this part is above the limit requirement of GB/T26572.

4.4.3 Taiwan Requirements — Taiwan RoHS

Taiwan RoHS refers to the Taiwan Bureau of Standards, Metrology and Inspection's (BSMI) requirements in standard CNS 15663, Guidance to reduction of the restricted chemical substances in electrical and electronic equipment. Seagate products must comply with the "Marking of presence" requirements in Section 5 of CNS 15663, effective January 1, 2018. This product is Taiwan RoHS compliant.

The following table meets the Section 5 "Marking of presence" requirements.

Table 22 Taiwan - Restricted Substances

設備名稱：硬盤設備 /SSD，型號：僅適用於內部使用 Equipment Name: Hard Disk Device/SSD, Type Designation: Internal Use Only						
單元 Unit	限用物質及其化學符號 Restricted Substance and its chemical symbol					
	鉛 (Pb)	汞 (Hg)	鎘 (Cd)	六價鉻 (Cr ⁺⁶)	多溴聯苯 (PBB)	多溴二苯醚 (PBDE)
印刷電路板組裝 PCBA	—	0	0	0	0	0
機殼 Chassis	—	0	0	0	0	0
備考 1. "0" 係指該項限用物質之百分比含量未超出百分比含量基準值。 Note 1. "0" indicates that the percentage content of the restricted substance does not exceed the percentage of reference value of presence. 備考 2. "—" 係指該項限用物質為排除項目。 Note 2. "—" indicates that the restricted substance corresponds to the exemption.						

4.5 Reference Documents

In case of conflict between this document and any referenced document, this document takes precedence.

Table 23 Reference Documents

	Location
PCIe specifications: PCIe - PCI Express Electromechanical specification, revision 3.0 NVMe - Non Volatile Memory Express specification 1.2a PCIe CEM - PCI Express Card Electromechanical specification, revision 1.1	www.pcisig.com www.nvmexpress.org
Trusted Computing Group (TCG) Documents TCG Storage Architecture Core Specification, Rev. 1.0 Storage Work Group Security Subsystem Class: Opal, Version 2.00"	www.trustedcomputinggroup.org
Solid State Drive Requirements and Endurance Test Methods JESD218 JESD219	www.jedec.org



Seagate Technology LLC

AMERICAS Seagate Technology LLC 10200 South De Anza Boulevard, Cupertino, California 95014, United States, 408-658-1000

ASIA/PACIFIC Seagate Singapore International Headquarters Pte. Ltd. 7000 Ang Mo Kio Avenue 5, Singapore 569877, 65-6485-3888

EUROPE, MIDDLE EAST AND AFRICA Seagate Technology SAS 16-18 rue du Dôme, 92100 Boulogne-Billancourt, France, 33 1-4186 10 00

Publication Number: 100810196, Rev. A

January 2018